

CEE - PLUGS, CONNECTORS AND SOCKETS

IP67 : Wall Socket



Description:

IP44:

Housing PA6

Material:

Contacts: Brass

To order nickel-plated contacts please add a "v" to the code
To order Turbo Twist Design (Screwless Connection Technology) please add a "TT" to the code

Specification: Screw Terminals

Watertight

Top and Rear entry

General Data:

Technical Data:

Area Large connection area

Enclosure High impact resistance material

Wired: Ready wired for use

Cable Entry: M25 - Top entry, \varnothing 25mm at the rear

All External Metal Made from stainless steel

Parts:

Typical Applications: Industrial



Connection
to the future

Technical Information and Photographs from PC Electric

Address: 4 Branch Road, Germiston 1401, P.O. Box 678, Germiston 1400

CEE - PLUGS, CONNECTORS AND SOCKETS

IP67 : Wall Socket

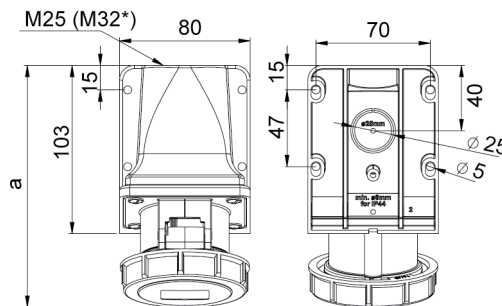

b=height
angle=15°

Product Information:

Amp.	Poles	Dimensions			Wire Flexible (mm ²)	Contact Screws (Ncm)	Solid (mm ²)	Weight (g)	Category No.	
		(mm)							(Screw Terminal)	(230V-)
		a	b	M*				50/60Hz, 3p=6h, 4p+5p=6h	50/60Hz, 3p=6h, 4p+5p=6h	
16	3	146	96	25	1-2.5	100Ncm	1-4	226	1132-6	
	4	148	99	25	1-2.5	100Ncm	1-4	241	1142-6	
	5	148	102	25	1-2.5	100Ncm	1-4	275	1152-6	
32	3	161	108	25	2.5-6	110Ncm	2.5-10	298	1236-6	
	4	161	108	25	2.5-6	110Ncm	2.5-10	314	1242-6	
	5	163	112	25	2.5-6	110Ncm	2.5-10	351	1252-6	



Connection
to the future

Technical Information and Photographs from PC Electric

Address: 4 Branch Road, Germiston 1401, P.O. Box 678, Germiston 1400

Complete your Project:

Please select the items you require and we will be in touch

Cables and Wires:

Indoor
Outdoor
General
Other
Let an ACTOM
Specialist Contact you

Lighting:

Indoor
Outdoor
General
Other
Let an ACTOM
Specialist Contact you

Transformers (Distribution):

Indoor
Outdoor
General
Other
Let an ACTOM
Specialist Contact you

Accessories:

Indoor
Outdoor
General
Other
Let an ACTOM
Specialist Contact you

Specific Information:

Address: 4 Branch Road, Germiston 1401, P.O. Box 678, Germiston 1400

For more Information on this Product Please Send us the Following

Product Information:

Product Name:

Quantity:

Project Name:

Date the Product is required:

Your Contact Information:

Name and Surname:

Company:

Email:

Phone Number:

Province:

Thank You

For having a Look at this Product

Please send this PDF back to us with all your Information

Scan the QR Code to visit our Website:

